



EXPLOSION PROOF PAINTING ROBOTS

The K-Series line of painting robots combines high operational performance with powerful programming flexibility. With seven explosion-proof models available, Kawasaki has a robot that will suit any robotic painting application, from a one robot paint cell to complete multi-robot integrated finishing systems.

KF121

| | |
|-----------------------------|----------------------|
| Payload | 5 kg |
| Horizontal Reach | 1,240 mm |
| Vertical Reach | 1,700 mm |
| Maximum Linear Speed | 1,500 mm/s |
| Wrist Type | RBR (Roll Bend Roll) |

Applications

- Painting



COMPREHENSIVE ROBOT LINE UP

Kawasaki offers seven unique explosion-proof painting robot models, from the KF121 for small applications to the KG264 for automotive inner and outer body finishing. All models are suited for hazardous environments such as spray painting and boast industry leading mean time between failures (MTBF).

HOLLOW WRIST ARMS

Hollow wrist versions of the K-Series robot arms can be fitted with internal hoses to minimize overspray that adheres to the piping, reducing the risk of contaminants in the paint finish. The inner diameter of the hollow wrist is either 40 mm or 70 mm.

PROGRAMMING FLEXIBILITY

K-Series Robots can be programmed in two ways, via the robot teach pendant or a computer, and using one of the two Kawasaki's programming methodologies, Block Step or AS Language. The Block Step programming method eliminates time consuming program teaching with auto-path generating software. The AS Language provides the programmer ultimate flexibility via a Basic like syntax through any word processor text file. The programmer can create advanced logic, manipulate program locations in addition to creating and controlling the painting process. AS Language programs can create powerful "decision making" robots.

EASY SYSTEM INTEGRATION

Kawasaki Robotics also offers a control panel to enhance the ease of system building and interfacing with peripheral equipment such as robot traveling unit, workpiece transfer unit, rotation unit, and other devices. The control panel is an intuitive graphical interface that allows users to centrally operate and control all components of the robotic finishing system. It provides real time status information and access to production management information such as line monitoring data, data setting and modification of the coating requirements and coating unit control panel, as well as statistical data on production, errors, paint consumption, etc.

EXTENSIVE PAINTING EXPERIENCE

Over 30 years of successful robotic painting experience has enabled Kawasaki to design robots to meet the needs of today's most demanding customers. The K-Series Robots are now equipped with more advanced application functions than ever offered before, resulting in increased productivity. Our highly skilled paint systems professionals have both process and technology experience and are available to support your paint automation project, from the initial planning stage right up to equipment start-up.

MOTION RANGE & DIMENSIONS

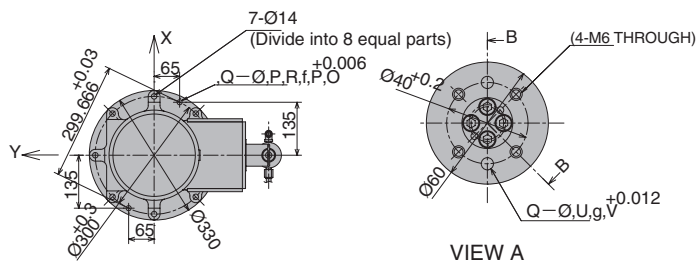
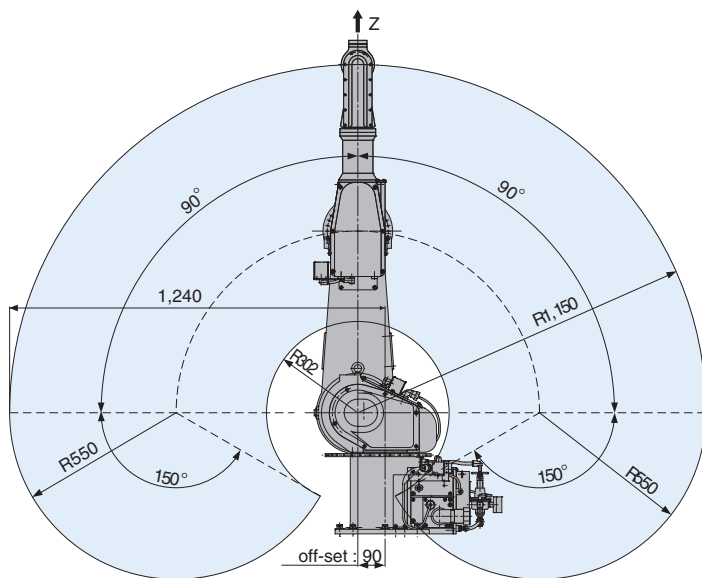

INSTALLATION DIMENSIONS

(mm)

Note: Detailed drawings are available upon request.

KF121 SPECIFICATIONS

| | | | |
|---|---|---------------------------------------|------------------------|
| Type | Articulated | | |
| Degrees of Freedom | 6 axes | | |
| Payload | 5 kg | | |
| Horizontal Reach | 1,240 mm * | | |
| Vertical Reach | 1,700 mm | | |
| Repeatability | ±0.2 mm | | |
| Maximum Linear Speed | 1,500 mm/s at robot flange | | |
| Wrist Type | RBR (Roll Bend Roll) | | |
| Work Envelope (degrees) & Maximum Speed (degrees/s) | Axis | Motion Range | Maximum Speed |
| | JT1 | ±160° | 220°/s |
| | JT2 | ±90° | 120°/s |
| | JT3 | ±150° | 240°/s |
| | JT4 | ±270° | 430°/s |
| | JT5 | ±145° | 430°/s |
| | JT6 | ±360° | 720°/s |
| Wrist Load Capacity | Axis | Maximum Torque | Moment of Inertia |
| | JT4 | 7.8 N·m | 0.17 kg·m ² |
| | JT5 | 7.8 N·m | 0.17 kg·m ² |
| | JT6 | 2.9 N·m | 0.06 kg·m ² |
| Motor(s) | Brushless AC Servomotor | | |
| Brakes | All axes | | |
| Hard Stop(s) | Adjustable mechanical stopper JT1 | | |
| Mass | 140 kg (excluding Options) | | |
| Body Color | Kawasaki Standard | | |
| Installation | Floor, ceiling | | |
| Environmental Conditions | Temperature | 0 ~ 40° C | |
| | Humidity | 35 ~ 85 % (no dew, nor frost allowed) | |
| Explosion Protection | Pressurized and intrinsically safe Class 1, Zone 1, Group IIB & T4 certified | | |
| Air Supply to Manipulator | Input quantity, pressure: 0.5 Nm ³ /min., 0.3~0.7 MPa Dew point: -17° C or less at atmospheric pressure | | |
| Options | Linear track options Riser (300/600 mm) Base plate Wall mount (arm rotation JT1 max. stroke: 120°) | | |

* Distance from the center of JT1 to the center of JT5

Simple friendly

Assembly • Cutting • Dispensing • Grinding • Handling • Inspection • Packaging • Painting • Palletizing • Polishing • Tending • Welding