



EXPLOSION PROOF PAINTING ROBOTS

The K-Series line of painting robots combines high operational performance with powerful programming flexibility. With seven explosion-proof models available, Kawasaki has a robot that will suit any robotic painting application, from a one robot paint cell to complete multi-robot integrated finishing systems.

KF262

Payload	wrist 12 kg, arm 20 kg
Horizontal Reach	2,665 mm
Vertical Reach	4,107 mm
Max. Painting Speed	1,200 mm/s
Wrist Type	BBR (Bend Bend Roll)

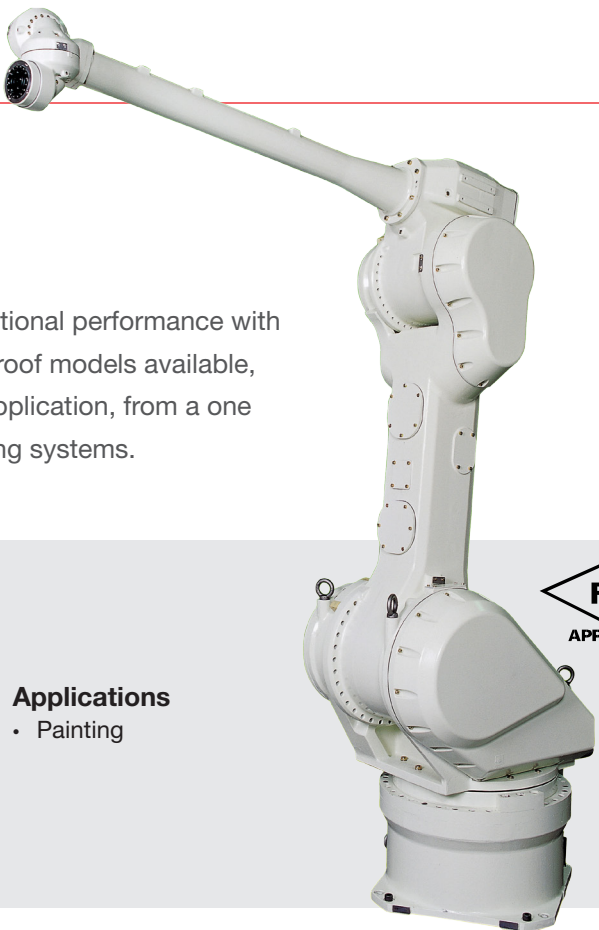

Applications

- Painting

COMPREHENSIVE ROBOT LINE UP

Kawasaki offers seven unique explosion-proof painting robot models, from the KF121 for small applications to the KG264 for automotive inner and outer body finishing. All models are suited for hazardous environments such as spray painting and boast industry leading mean time between failures (MTBF).

HOLLOW WRIST ARMS

Hollow wrist versions of the K-Series robot arms can be fitted with internal hoses to minimize overspray that adheres to the piping, reducing the risk of contaminants in the paint finish. The inner diameter of the hollow wrist is either 40 mm or 70 mm.

PROGRAMMING FLEXIBILITY

K-Series Robots can be programmed in two ways, via the robot teach pendant or a computer, and using one of the two Kawasaki's programming methodologies, Block Step or AS Language. The Block Step programming method eliminates time consuming program teaching with auto-path generating software. The AS Language provides the programmer ultimate flexibility via a Basic like syntax through any word processor text file. The programmer can create advanced logic, manipulate program locations in addition to creating and controlling the painting process. AS Language programs can create powerful "decision making" robots.

EASY SYSTEM INTEGRATION

Kawasaki Robotics also offers a control panel to enhance the ease of system building and interfacing with peripheral equipment such as robot traveling unit, workpiece transfer unit, rotation unit, and other devices. The control panel is an intuitive graphical interface that allows users to centrally operate and control all components of the robotic finishing system. It provides real time status information and access to production management information such as line monitoring data, data setting and modification of the coating requirements and coating unit control panel, as well as statistical data on production, errors, paint consumption, etc.

EXTENSIVE PAINTING EXPERIENCE

Over 30 years of successful robotic painting experience has enabled Kawasaki to design robots to meet the needs of today's most demanding customers. The K-Series Robots are now equipped with more advanced application functions than ever offered before, resulting in increased productivity. Our highly skilled paint systems professionals have both process and technology experience and are available to support your paint automation project, from the initial planning stage right up to equipment start-up.

MOTION RANGE & DIMENSIONS

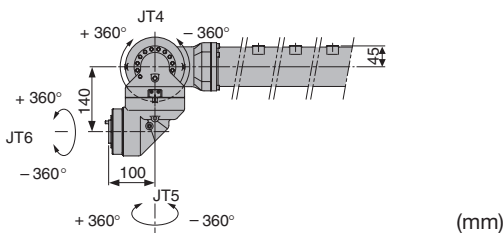
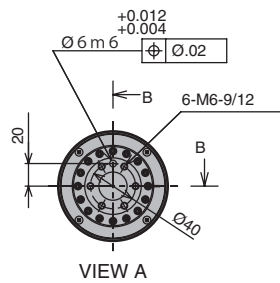
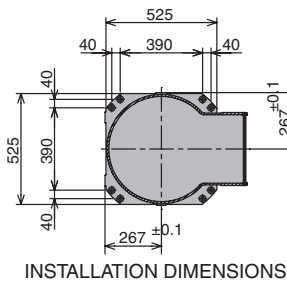
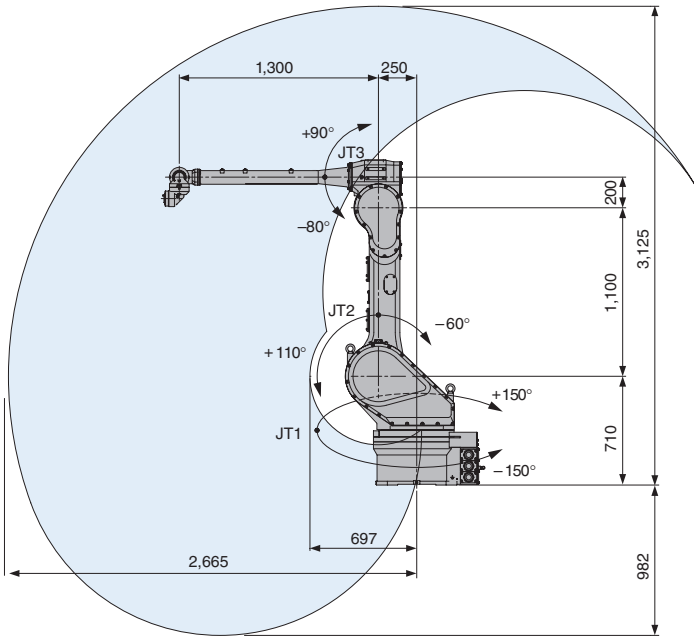

Note: Detailed drawings are available upon request.

Simple  friendly

KF262 SPECIFICATIONS		
Type	Articulated	
Degrees of Freedom	6 axes	
Payload	Wrist 12 kg, arm 20 kg	
Horizontal Reach	2,665 mm *	
Vertical Reach	4,107 mm	
Repeatability	±0.5 mm	
Maximum Linear Speed	2,000 mm/s at robot flange	
Maximum Painting Speed	1,200 mm/s at the center of tool mounting surface	
Wrist Type	BBR (Bend Bend Roll)	
Work Envelope (degrees) & Maximum Speed (degrees/s)	Axis	Motion Range
	JT1	±150°
	JT2	+110° ~ -60°
	JT3	+90° ~ -80°
	JT4	±360°
	JT5	±360°
Wrist Load Capacity	Axis	Maximum Torque
	JT4	33.3 N·m
	JT5	28.8 N·m
Wrist Load Capacity	Axis	Moment of Inertia
	JT4	1.28 kg·m ²
	JT5	0.96 kg·m ²
Motor(s)	Brushless AC Servomotor	
Brakes	All axes	
Hard Stop(s)	Adjustable mechanical stopper JT1	
Mass	720 kg (excluding Options)	
Body Color	Kawasaki Standard	
Installation	Floor, wall, ceiling	
Environmental Conditions	Temperature	0 ~ 40° C
	Humidity	35 ~ 85 % (no dew, nor frost allowed)
Explosion Protection	Pressurized and intrinsically safe Class 1, Zone 1, Group IIB & T4 certified	
Air Supply to Manipulator	Input quantity, pressure: 0.5 Nm ³ /min., 0.4~0.7 MPa Clean and dry air: Solid material: 0.01 µm or less Oil content: mist separation 99.9999% or more Dew point: -17° C or less at atmospheric pressure	
Options	Linear track options Riser (300/600 mm) Base plate Adjustable mechanical stopper JT2/JT3 Jig set for zeroing	

* Distance from the top arm center line to the JT4 axis