

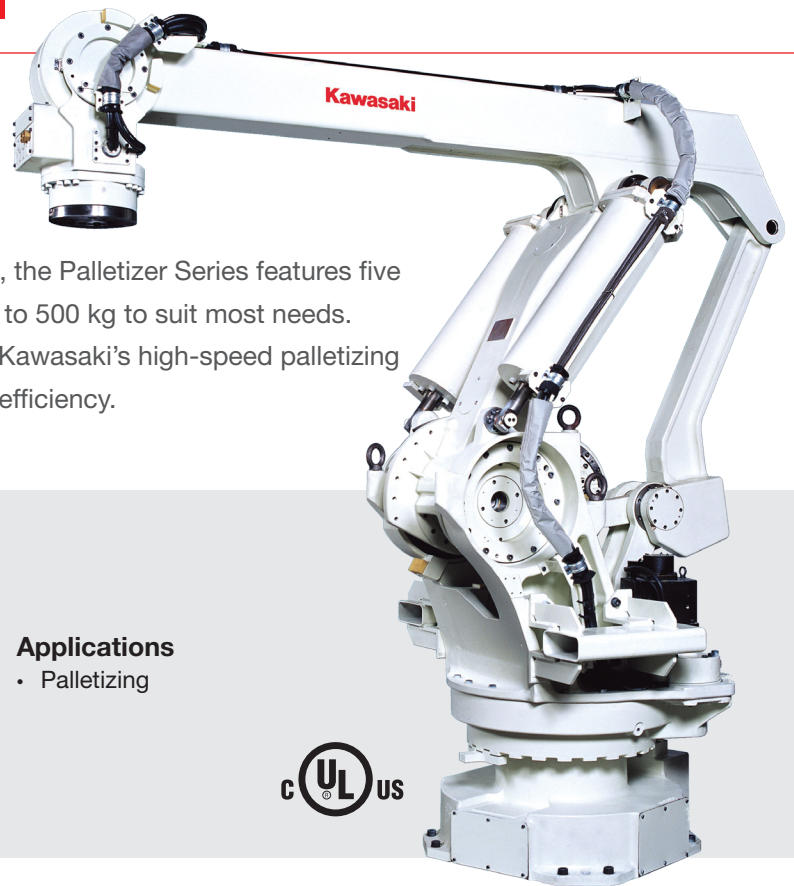

## HIGH-PERFORMANCE PALLETIZING ROBOTS



Designed specifically for palletizing applications, the Palletizer Series features five unique robots with payload capacity from 80 kg to 500 kg to suit most needs. With industry leading work range and reliability, Kawasaki's high-speed palletizing robots help companies improve production line efficiency.

# MDE500N

<b>Degrees of Freedom</b>	5 axes
<b>Payload</b>	500 kg
<b>Horizontal Reach</b>	3,142 mm
<b>Vertical Reach</b>	3,521 mm
<b>Repeatability</b>	±0.5 mm

**Applications**  
• Palletizing



## HIGH-PERFORMANCE

In today's highly competitive marketplace, meeting the demand for just-in-time deliveries, flexible packaging, the freshest products, and the highest production line efficiencies are all key to a company's success. Kawasaki Robotics helps support these success factors with robots designed specifically for palletizing applications. Robots model number RD80N, ZDE130S, ZDE250S, MDE400N and MDE500N offer a wide range of payload options (80 kg to 500 kg) along with industry leading reach, speed and quality to deliver high-performance automation technology for most any palletizing application.

## HIGH-SPEED OPERATION

The Kawasaki Palletizing Robots are among the fastest and most reliable machines in the industry. The RD80N Robot is capable of 900 cycles per hour with an 80 kg payload and the ZDE130S Robot is capable of 1,800 cycles per hour with a 60 kg payload.

## COMPACT APPLICATIONS

The Kawasaki RD80N is designed specifically for applications where a compact, high-speed, palletizing robot is required. Despite its slim space-saving design, the RD80N can manipulate loads up to 80 kg and create pallet stacks over seven feet tall. The unique 5-axis design can be floor or ceiling mounted and is ideal for palletizing, depalletizing, material handling, and case packing applications.

## LARGE WORK ENVELOPE WITH HIGH PAYLOAD

The ZDE130S and ZDE250S robots can manipulate products vertically up to 3,075 mm, while the MDE400N and MDE500N robots have up to 3,521 mm of vertical range. The high vertical reach capability is ideal for tall pallet creation and multi-lane applications where the robot is required to reach over incoming and outgoing production lines. Kawasaki Palletizing Robots have a horizontal reach of up to 3,255 mm, which is the longest reach in their class. This extra long reach allows for one Kawasaki robot to be used in applications where five or more outgoing pallet lanes are required. This unique capability contributes to the flexibility and efficiency of the Kawasaki Palletizing Robot design.

The Z-Series models are ideal for typical medium to heavy palletizing loads, while the high capacity M-Series robots can handle up to 500 kg. The high payload capabilities of these robots allow for multiple product picks and complete pallet layer handling, resulting in fewer cycles per completed pallet.

## MOTION RANGE & DIMENSIONS

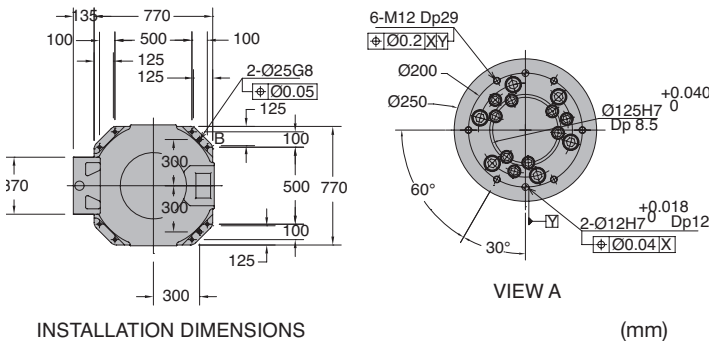
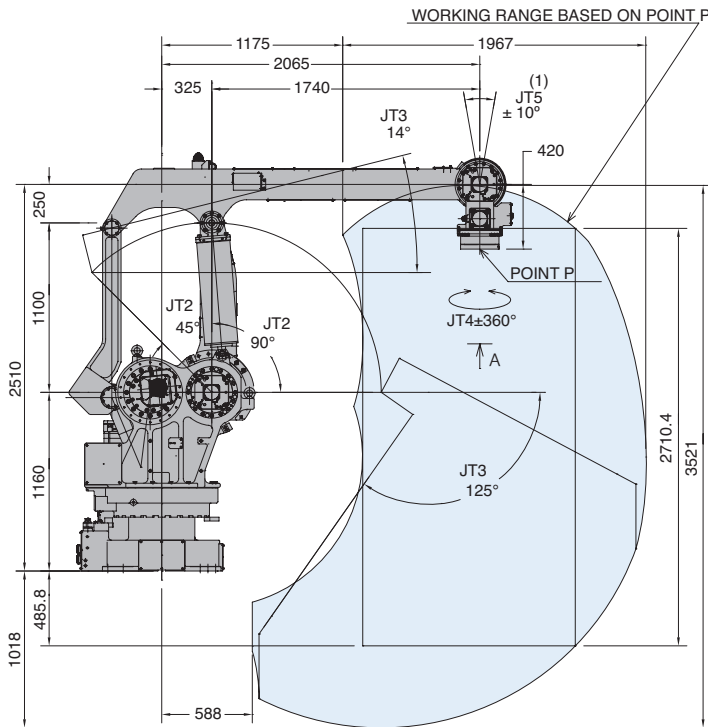

**Note:** Detailed drawings are available upon request.

Simple  friendly

## MDE500N SPECIFICATIONS

Type	Articulated		
Degrees of Freedom	5 axes		
Payload	500 kg		
Horizontal Reach	3,142 mm		
Vertical Reach	3,521 mm		
Repeatability	±0.5 mm		
Maximum Linear Speed	2,000 mm/s at robot flange		
Work Envelope (degrees) & Maximum Speed (degrees/s)	Axis	Motion Range	Maximum Speed
	JT1	±180°	70°/s
	JT2	+90° ~ -45°	65°/s
	JT3	+14° ~ -125°	45°/s
	JT4	±360°	160°/s
Wrist Load Capacity	Axis	Maximum Torque	Moment of Inertia
	JT4	—	250 kg·m <sup>2</sup>
Maximum Palletizing Capacity	Approx. 600 cycles/hour at 500 kg payload Based on a robot stroke of 400 mm upward-downward and 2,000 mm in the right-left direction.		
Motor(s)	Brushless AC Servomotor		
Brakes	All axes		
Hard Stop(s)	Adjustable mechanical stopper JT1		
Limit Switch	End of stroke limit switch JT1		
Mass	2,680 kg (excluding Options)		
Body Color	Kawasaki Standard		
Installation	Floor (includes fork pockets)		
Environmental Conditions	Temperature	0 ~ 45° C	
	Humidity	35 ~ 85 % (no dew, nor frost allowed)	
	Vibration	Less than 0.5 G	
Built-in Harness	Sensor harness 4 inputs, 24VDC, GND Valve harness 8 outputs		
Built-in Utilities	Pneumatic piping (ø12 x 2 lines)		
Options	<ul style="list-style-type: none"> <li>Linear track options</li> <li>Base plate</li> <li>Adjustable mechanical stopper JT2/JT3</li> <li>Limit switch JT2/JT3</li> <li>Sensor harness 16 inputs (replaces built-in standard)</li> <li>Double/single solenoid valves (2 units max.)</li> <li>Air cleaning equipment (filter, regulator, mist separator)</li> <li>EOAT for box gripping</li> <li>EOAT for bag gripping</li> <li>EOAT for vacuum blower</li> <li>Pneumatic piping for blower (ø1 inch x 1 line)</li> </ul>		